

**DC88X**  
**DOUBLE CYLINDER**  
**E163HX**

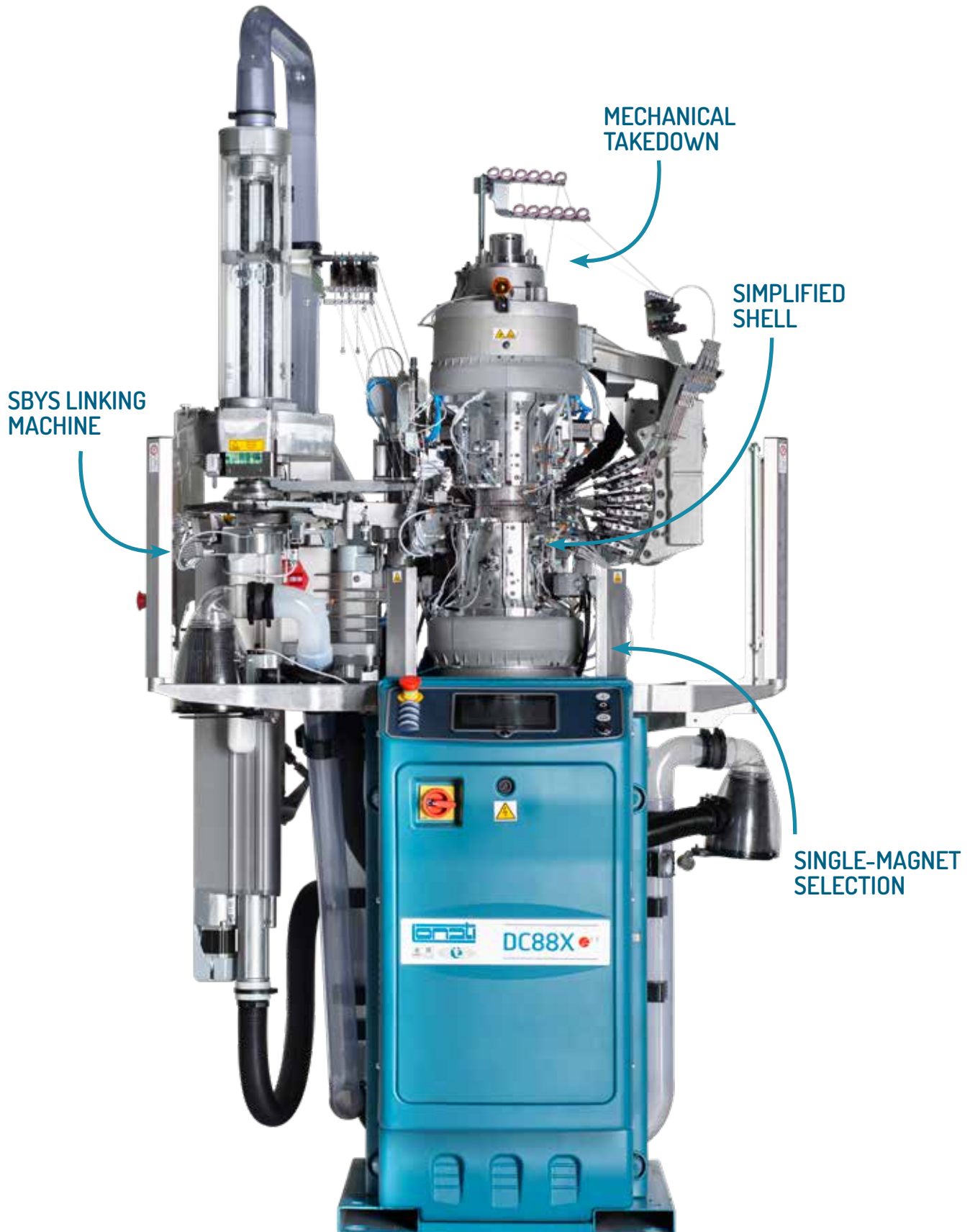

# DOUBLE CYLINDER

E163HX



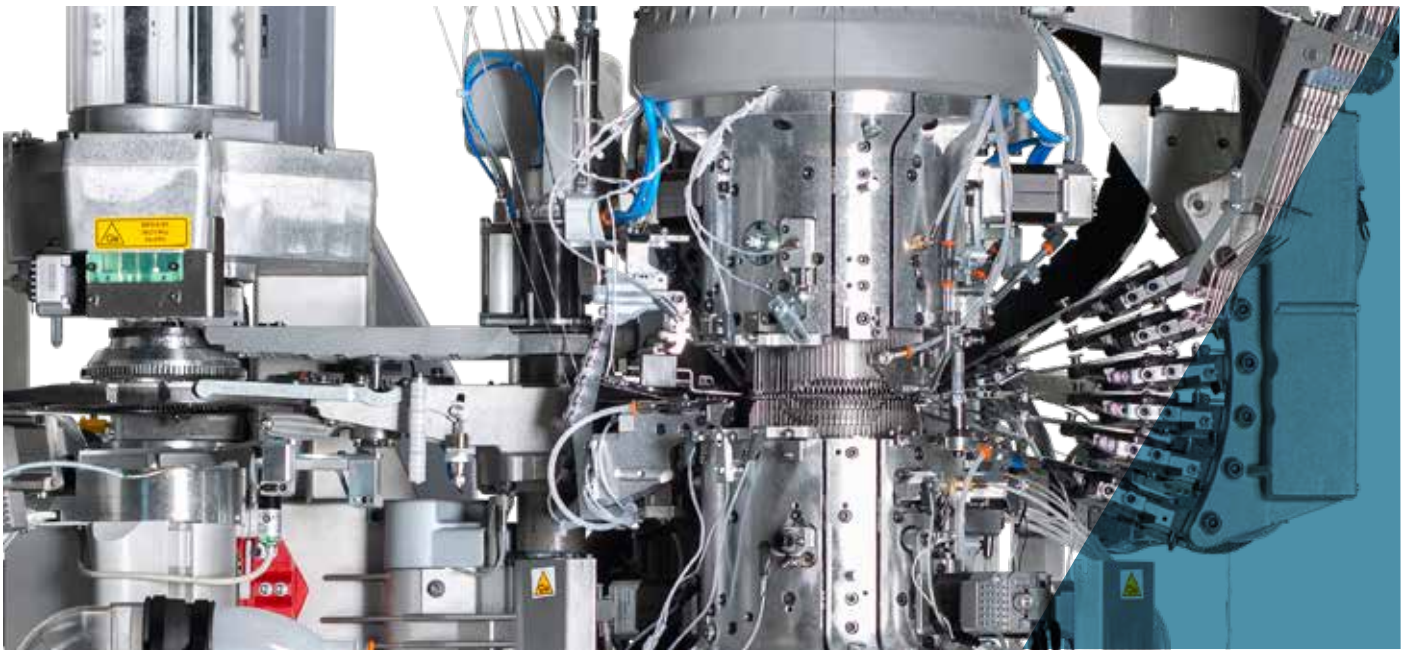

All images in this brochure are indicative and not binding.

## DOUBLE CYLINDER E163HX

Double cylinder 2 feeds machine for the production of men's, women's and children's socks in ribs, plain knit, Links and Links Jacquard. Needle-needle single-magnet actuator selection for several rib, Links and Links Jacquard patterns. Brushless motor incorporated in the column with variable heel and toe reciprocating motion. 2 selection points instead of pickers and needle droppers. Heavy sock roller pull-out device with Lonati "SbyS" true linking. Articles, sizes and knit designs are programmable by using a Personal Computer and the powerful Software Digraph 3+ package. Graphic display keyboard for the selection of articles and additional operations. Possibility of connection to the NAUTILUS for the production data detection and for a real-time monitoring of the knitting room. A available in 4" ½ diameter and gauges from 5 to 8.

- Needle-needle single-magnet actuator selection instead of pickers and needle droppers and links drums for different rib and links patterns
- Toe linking performed by SbyS linking machine
- Easier sinkers maintenance thanks to the rotating knitting head in standby position
- Stitch cams with independent stepper motors
- Mechanical takedown
- Simplified shell

### MACHINE DIMENSIONS



Length 119 cm + yarn creel 10.5 cm  
Depth 109 cm + yarn creel 67 cm  
Height 240 cm + yarn creel 20 cm

### MACHINE WEIGHT



Machine ca. 460 Kg  
Yarn creel ca. 30 Kg

### NOTE:

All data relating to outer appearance, performance, dimensions and weight are just as an indication.

# DOUBLE CYLINDER

## E163HX

### TECHNICAL DATA

MODEL	CYLINDER DIAMETER	GAUGE	NEEDLE THICKNESS
E163HX	4"1/2	from 5 to 8	1.10 mm

Above data are indicative and not binding.

### STANDARD DEVICES

- Single-magnet actuator electronic selection system
- Mechanical take-down
- Multi-stiffening by means of stepper motors
- High heel
- Sinker cap with internal lubrication
- 6 pneumatic yarnfingers on first feed and 2 on second feed
- Suction valve controlled with stepper motor
- USB port
- Yarn-rack
- SbyS sewing device

### MAIN OPTIONAL DEVICES

- LGL ECO POWER feeders
- Dinema YoYo positive feeder
- Dinema ISPY yarn-sliding sensors
- Cassefils mechanical sensors
- Anti-pulling sensors
- Ethernet board
- Shadow rib
- Suction fan

### SUITABLE YARNS

The machine is designed to be used with the following yarns:

- Natural fibers
- Syntetic yarn
- Elastic yarn

### POSSIBLE KNITTING

The standard machine can perform the following knittings

- Plain knit
- Rib
- Links
- Links Jacquard
- 1st feed tuck stitch
- Open work (optional)
- Shadow rib (optional)

# DOUBLE CYLINDER

## E163HX

### NUMBER OF COLORS

Number of colors	1 color on the same course Up to 5 colors on first feed Up to 2 colors on second feed
------------------	---

### PERFORMANCES

GAUGE	4" CYLINDER DIAMETER
KNITTING FEATURES	5 - 6 - 7 - 8 (needle thickness 1,10mm)
	LINKS = 200 Rpm
	Rib and plain knit = 200 Rpm
	Tuck stitch = 200 Rpm
	Reciprocated motion = 200 Rpm
	Jacquard = 200 Rpm

Above data are indicative and not binding.

### GAUGE

Model	Ø	GAUGE			
		5	6	7	8
163HX	4 1/2"	72 76	80 84 88	92 96 100 104	108 112 116 120
Needle thickness 1,10					

Above data are indicative and not binding.

#### DISCLAIMER:

For gauges lower or higher than those in the chart, their maximum speed must be reduced by 10-15%.  
Should you use staple fiber, maximum speed has to be detected each time according to the yarn and the item to be produced.

# DOUBLE CYLINDER

## E163HX

### NOISE LEVEL

Machine average noise level, suction included n.d.

### LUBRICANTS

Average consumption for 100 dozens= 330 gr. Lonati recommends: Kluber Madol 183 Supreme

### GREASE

For seals, bearing etc Lonati recommends: Damping grease Nyogel 774F

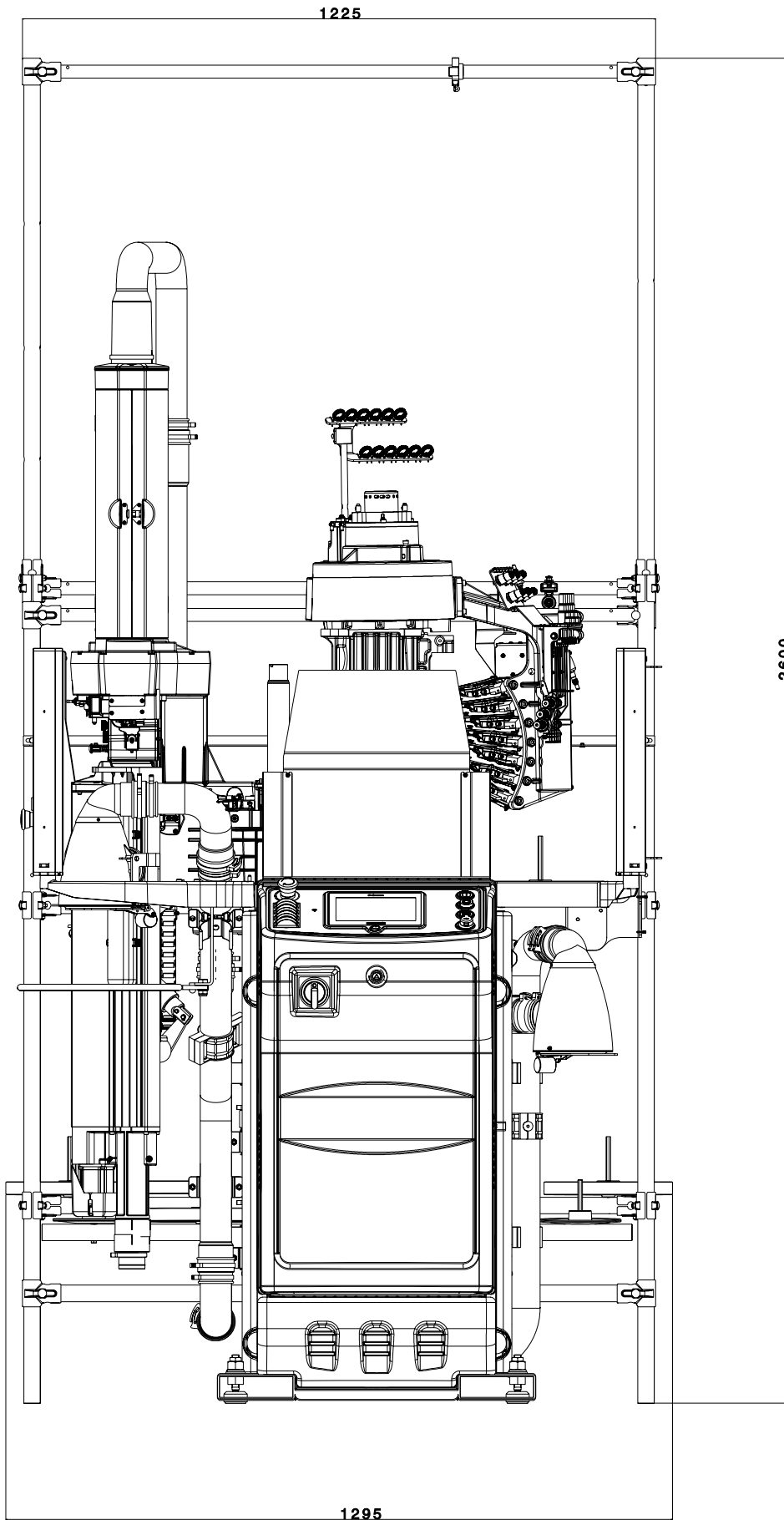

### FRONT VIEW

Machine dimensions + 16 positions yarn creel.

### NOTE:

The picture may show fittings and equipment that are supplied on demand and not.



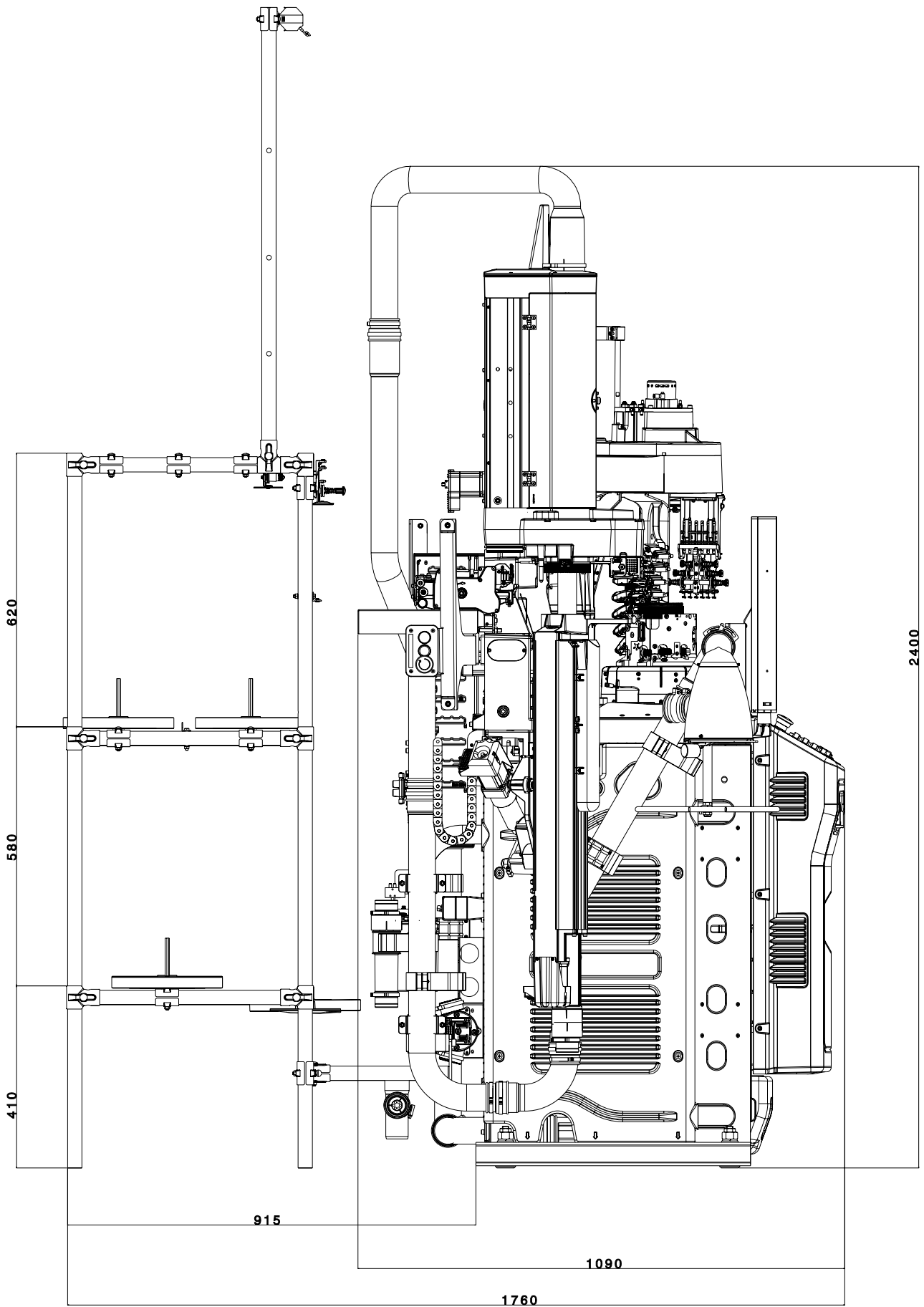

#### SIDE VIEW

Machine dimensions + 16 positions yarn creel.

#### NOTE:

The picture may show fittings and equipment that are supplied on demand and not.







**LONATI SPA**

Via Francesco Lonati, 3 | 25124 Brescia (Italy)  
Tel. +39 03023901 | Fax +39 030 2310024  
C.F.: 01469680175 | P.iva: 02096730961  
info@lonati.com - www.lonati.com