

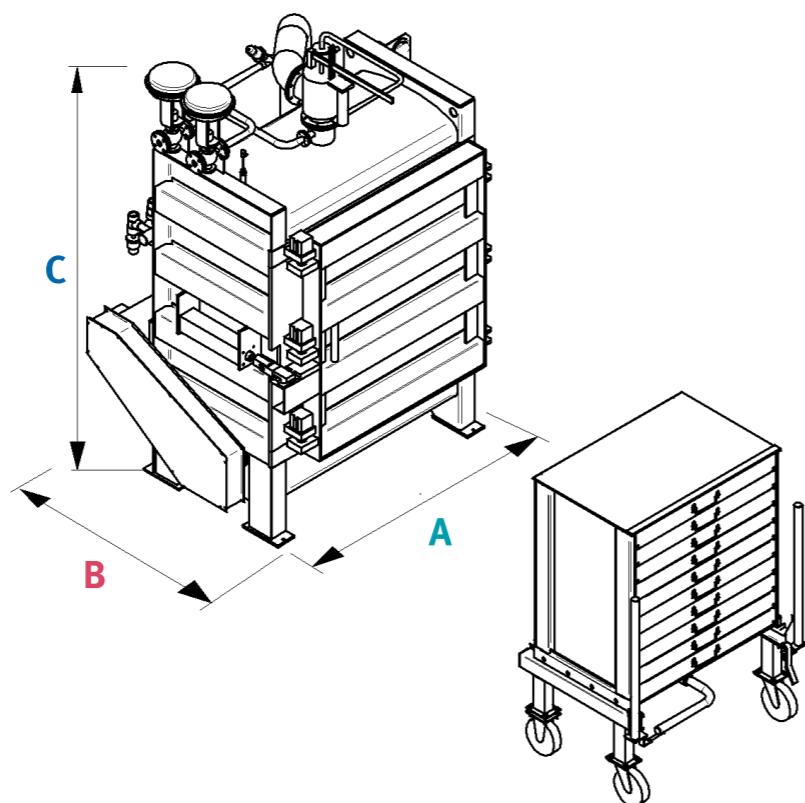

TABELLA ATC/HT

CARICO NOMINALE IN TINTURA NOMINAL LOAD	Kg.	4	20	60	120	240
PRESSIONE DI PROGETTO DESIGN PRESSURE	Bar	0,5	0,5	0,5	0,5	0,5
PRESSIONE DI LAVORO WORKING PRESSURE	Bar	0,45	0,45	0,45	0,45	0,45
NUMERO PORTE NUMBER OF DOORS		1	1	1	1	2
NUMERO CASSETTI NUMBER OF DRAWERS		4	6	10	10	10+10
DIMENSIONI CASSETTI DRAWERS DIMENSION	mm	300 x 350 x 100(H)	500 x 500 x 120(H)	1000 x 500 x 120(H)	1000 x 1000 x 120(H)	1000 x 1000 x 120(H)
POTENZA INSTALLATA INSTALLED POWER	KW	3	4	10	15	20
LARGHEZZA MACCHINA MACHINE LENGTH	A mm	1400	1150	1850	1850	2900
PROFONDITÀ MACCHINA MACHINE DEPTH	B mm	600	1350	1600	2150	2200
ALTEZZA TOTALE MACCHINA TOTAL HEIGHT	C mm	1300	2000	2800	2800	2800

Dati indicativi - Non binding details



Flainox s.r.l.

Macchine tessili per tintoria e finissaggio - 13854 Quaregna (BI) - Italy - Via G. Leopardi, 5
Tel. +39 015.98.06.80 - Fax +39 015.94.771 - e-mail: comm@flainox.com - www.flainox.com

L'eleganza del colore
The elegance of the colour



www.modesit.it



Vista di alcuni impianti
View of certain plants
Vista de algunas instalaciones
设备视图

Macchina ad alto spessore per la tintura di collants tipo "ATC/HT" a rapporto bagno corto

- Le macchine, nella varie versioni, possono essere dotate di:
- Pressurizzazione con cuscino d'aria oppure a ricircolo esterno del bagno
 - Cassetti per la tintura di materiale pre-fissato
 - Cestelli per la tintura di materiale in sacchi o in alternativa griglie posizionabili direttamente in macchina oppure utilizzando lo stesso, cestello porta-cassetti
 - Costruzione ad una oppure due porte
 - Dispositivi ed attrezzature varie per la riduzione sino al 50% del carico nominale a rapporto bagno costante

Una macchina molto versatile ed in grado di produrre calzetteria di alta qualità e finezza!

Machine at high thickness for the dyeing of pantyhose type "ATC/HT" with short bath ratio

- The machines, in the various versions, may be equipped with:
- Pressurisation by air pad or by external recirculation of dye bath;
 - Drawers for the dyeing of pre-boarded material;
 - Carriers for the dyeing of material in bags or, in alternative, grids to be positioned directly inside the machine or using same carrier for drawers.
 - Construction at one or two doors;
 - Devices and accessories to reduce the nominal load till 50% with constant bath ratio.

In short, a very versatile machine able to produce high quality and refinement hosiery.

Vista di alcuni impianti
View of certain plants
Vista de algunas instalaciones
设备视图

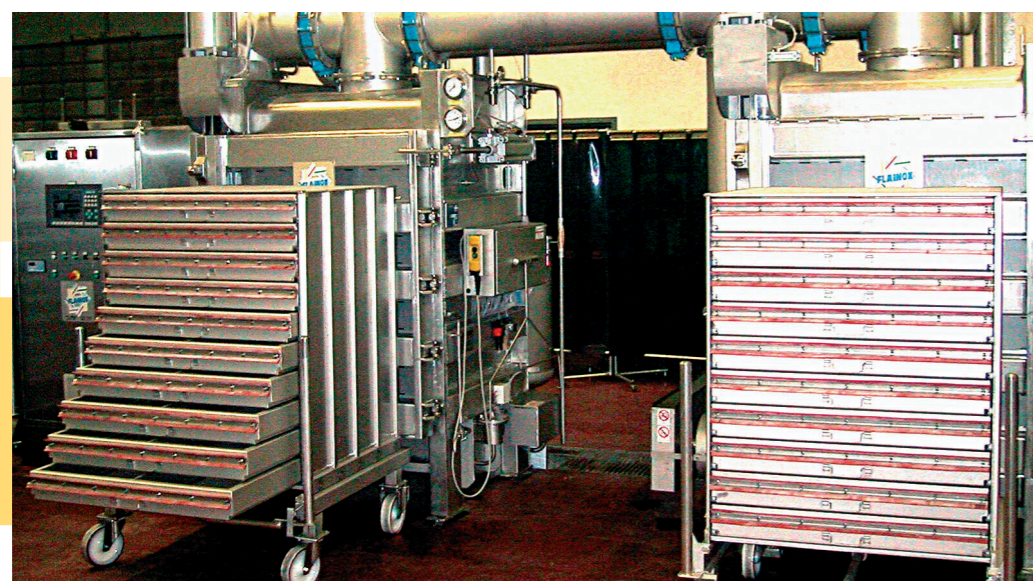

Máquina de alto espesor para la tintura de pantys tipo "ATC/HT" de relación baño corto

- Las máquinas, en sus varias versiones, pueden estar equipadas con:
- Presurización con colchón de aire o de recirculación externo del baño
 - Cajones para la tintura de material pre-fijado
 - Cestos para la tintura de material en bolsas o, en alternativa, rejas que se pueden posicionar directamente en la máquina o utilizando el mismo cesto porta-cajones
 - Construcción con una o con dos puertas
 - Dispositivos y herramientas varias para la reducción de hasta el 50% de la carga nominal con una relación de baño constante

¡En fin, una máquina muy versátil y en condiciones de producir medias de elevada calidad y fineza!



高温高压染色机 (ATC/HT) 是由5毫米钢板制成, 用于低浴比高档丝袜染色。

- 配以氣衬或染缸再循環外置系統增壓
- 抽屜式供已預定之織物進行染色
- 配以特定之載具供袋式織物染色, 或以載板設置於染機內, 或以抽屜式共用載具供袋式染色
- 以單門或雙門設計
- 設置供在染色織物只達染機設計容量一半以內時, 保持固定之浴比

總言之, 此是一多功能染色機可供生產高質量及敏感性高的襪類

