



Santoni

One Piece Sewing System

Sistema automatico per la cucitura della banda elastica sul collant "ONE PIECE" e delle punte.

Automatic system for elastic band and toes seaming on "ONE PIECE" pantyhose.

Patent Pending



- Cucitura con sistema brevettato Santoni FlatLock.
- Utilizzo di bande elastiche pronte o da rotolo, con sistema opzionale di taglio, cucitura ed alimentazione automatica.
- Opzione di collegamento automatico ad una macchina cucipunte TC Smart per la cucitura arrotondata "bocca di pesce".
- Applicazione della balza anche su collant realizzati su telaio Raschel.
- Produttività media 35 Dz/hr
- Patented seaming system Santoni FlatLock.
- Working with "ready to use" elastic bands or from a roll with an optional system for cutting, sewing and automatic feeding.
- Option for automatic linking to a toe closer TC Smart for round toes "fish mouth".
- Elastic band application also on pantyhose coming from warp knitting.
- Productivity on average 35 Dz/hr.

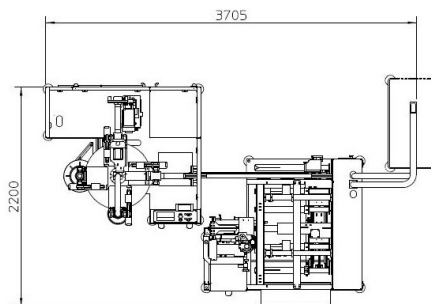



Santoni

One Piece Sewing System

Santoni FlatLock



Santoni FlatLock



Fish-mouth Toe



Santoni S.p.A. Via Carlo Fenzi, 14 - 2135 Brescia, Italy
Tel.: +39 030-376 711 Fax: +39 030-376 7242 E-mail: sales@santoni.com

