



Santoni

OP Smart

Sistema automatico per la cucitura della banda elastica sul collant “ONE PIECE” e sulle calze autoreggenti.

Automatic system for elastic band seaming on “ONE PIECE” pantyhose and hold-ups.

- Cucitura con sistema brevettato Santoni FlatLock.
- Utilizzo di bande elastiche pronte o da rotolo, con sistema opzionale di taglio, cucitura ed alimentazione automatica.
- Opzione di collegamento automatico ad una macchina cucipunte..
- Applicazione della balza anche su collant realizzati su telaio Raschel.
- Produttività media 35 Dz/hr
- Patented seaming system Santoni FlatLock.
- Working with “ready to use” elastic bands or from a roll with an optional system for cutting, sewing and automatic feeding.
- Option for automatic linking to a toe closer.
- Elastic band application also on pantyhose coming from warp knitting.
- Productivity on average 35 Dz/Hr.

Patent Pending



Santoni S.p.A. Via Carlo Fenzi, 14 - 2135 Brescia, Italy

Tel.: +39 030-376 711 Fax: +39 030-376 7242 E-mail: sales@santoni.com





Santoni

OP Smart

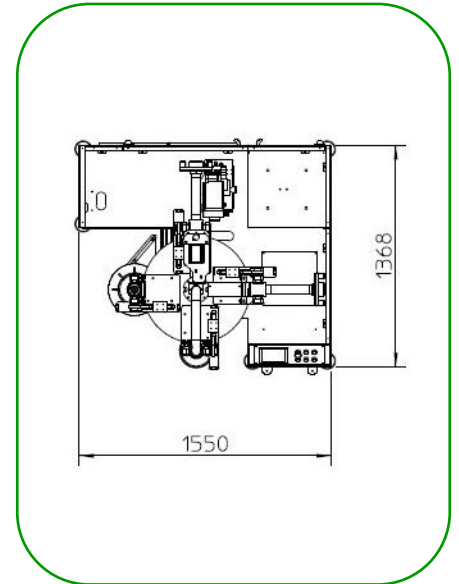

Santoni FlatLock Seaming

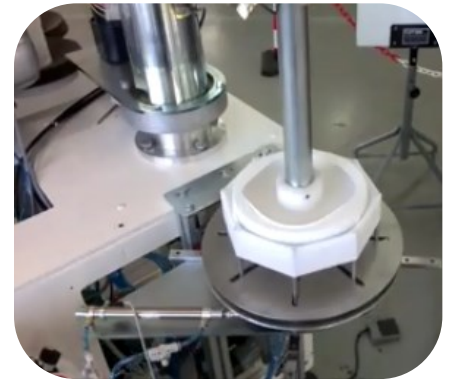

PRESSIONE ARIA	AIR PRESSURE	6 bar
CONSUMO ARIA	AIR CONSUMPTION	200 NI/min
ENERGIA ASSORBITA	ABSORBED POWER	2 Kw
PRODUZIONE MEDIA	AVG. PRODUCTION	35 Dz/hr

Santoni S.p.A. Via Carlo Fenzi, 14 - 2135 Brescia, Italy
 Tel.: +39 030-376 711 Fax: +39 030-376 7242 E-mail: sales@santoni.com



Note e caratteristiche tecniche di questo depliant non sono impegnative per la Santoni S.p.A. Soggetto a modifiche senza preavviso
 All technical specifications and features included in this brochure are not binding to Santoni S.p.A. Specifications subject to change without notice