



Vista di alcuni impianti
View of certain plants
Vista de algunas instalaciones
设备视图

Apparecchio ovale per la tintura della maglieria confezionata – AOM/C-WOOL

- L'apparecchio è particolarmente adatto per la tintura della maglieria di:
- LANA
 - LANA PETTINATA TRATTATA IRRESTRINGIBILE;
 - LANA / ACRILICO;
 - LANA / ANGORA;
 - CALZETTERIA;
 - PURA SETA;
 - TRATTAMENTO IRRESTRINGIBILE;
 - TRATTAMENTO FOLLATURA.

Oltre alla versione standard, l'apparecchio può essere costruito con dispositivo a doppia pala per potenziare la circolazione del bagno, aumentare la produttività del 20% e tingere anche capi maglieria di cotone.

Side-paddles machine for dyeing ready made knitwear – AOM/C-WOOL

- The machine is particularly suitable for dyeing:
- WOOL (Lambswool – Shetland);
 - UNSHRINKABLE WORSTED WOOL;
 - WOOL IN BLEND WITH ACRYLIC;
 - WOOL IN BLENDS WITH ANGORA;
 - SOCKS;
 - PURE SILK;
 - MACHINES WASHING RESISTANT PROCESS;
 - MILLING TREATMENT.

Besides the standard version, the machine can be fitted with double paddle device to strengthen bath circulation, to increase productivity of the 20% and to dye, also, knitted cotton garments.

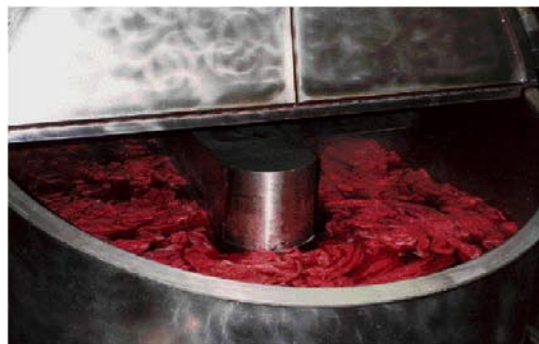

Vista di alcuni impianti
View of certain plants
Vista de algunas instalaciones
设备视图



Aparato oval para el teñido de géneros de punto confeccionados – AOM/C-LANA

- El aparato es particularmente adecuado para el teñido de géneros de punto de:
- LANA
 - LANA PEINADA CON TRATAMIENTO "INENCOGIBLE";
 - LANA / ACRÍLICO;
 - LANA / ANGORA;
 - MEDIAS;
 - PURA SEDA;
 - TRATAMIENTO "INENCOGIBLE";
 - TRATAMIENTO BATANADO.

Además del modelo estándar, el aparato puede fabricarse con un dispositivo de doble paleta para potenciar la circulación del baño, aumentar la productividad en un 20% y teñir prendas de punto de algodón.

侧桨式针织成衣染色机 – AOM/C-WOOL

- 这染色机特别适合于染下列衣物:
- 羊毛 (羔羊毛-雪兰毛);
 - 防缩精纺羊毛;
 - 羊毛/晴纶混纺;
 - 羊毛/安哥拉毛混纺;
 - 袜子;
 - 纯真丝;
 - 抗机洗加工工序;
 - 缩绒处理。

除了标准配置外, 也可配置双桨以加强染液的循环, 使产量增加20%和具备棉针织衣物的染色能力。

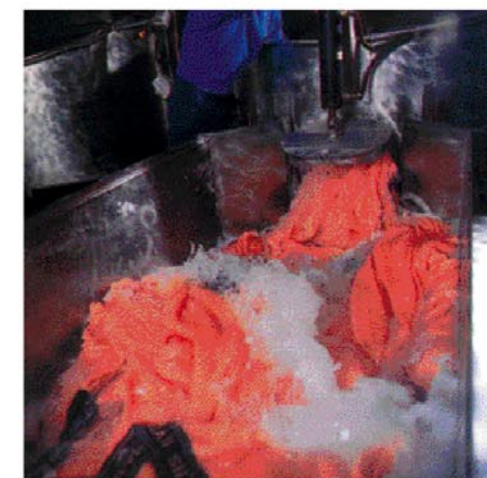
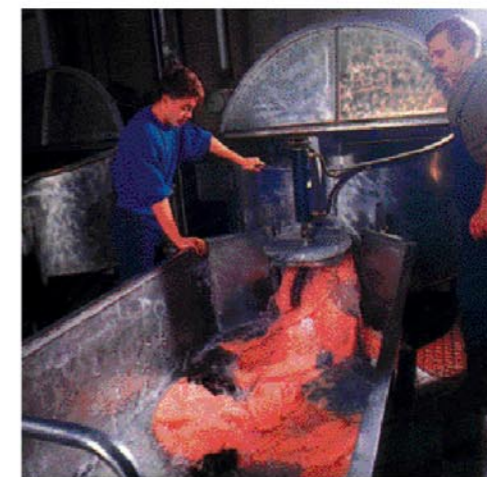

AOM/C-WOOL

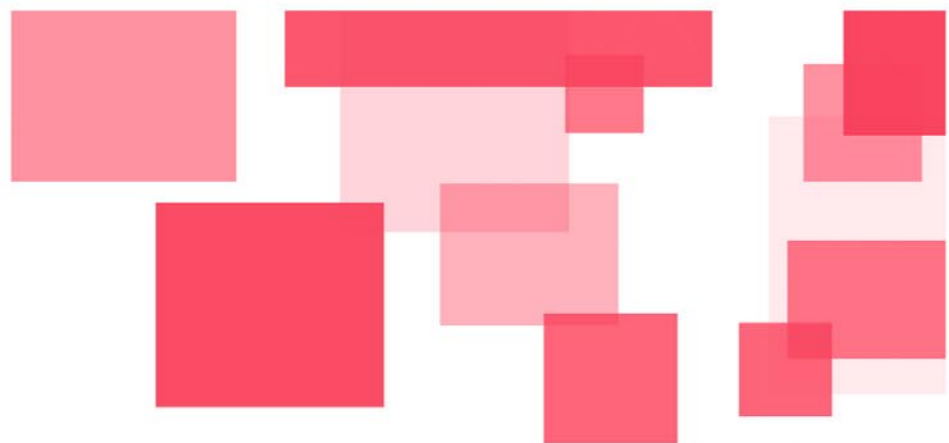

La delicatezza del colore
The delicacy of the colour

TABELLA AOM/C-WOOL

CAPACITA' CAPACITY	Lt.	130	250	600	1000	1600	2000	2600	3200	4000	5000
CARICO NOMINALE IN TINTURA NOMINAL LOAD	Kg.	4	7	20	40	60	80	100	120	150	200
POTENZA INSTALLATA ENGAGED POWER	Kw	0,5	0,5	1	1,5	2,0	2,0	3,5	3,5	3,5	4,0
LARGHEZZA MACCHINA MACHINE LENGTH	A mm	1000	1000	1300	1650	1950	2250	2250	2400	2500	2500
PROFONDITÀ MACCHINA MACHINE DEPTH	B mm	1300	1600	2000	2450	3400	3700	3900	4000	4200	5000
ALTEZZA TOTALE MACCHINA TOTAL HEIGHT	C mm	1200	1200	1300	1550	1750	1850	2000	2000	2200	2200
DIMENSIONI DIMENSIONS	D mm	/	/	/	4500	5400	5700	5900	6000	6200	7000
SECONDA PALA OPTIONALE OPTIONAL SECOND PADDLE		NO	NO	NO	YES	YES	YES	YES	YES	YES	YES

Dati indicativi - Non binding details

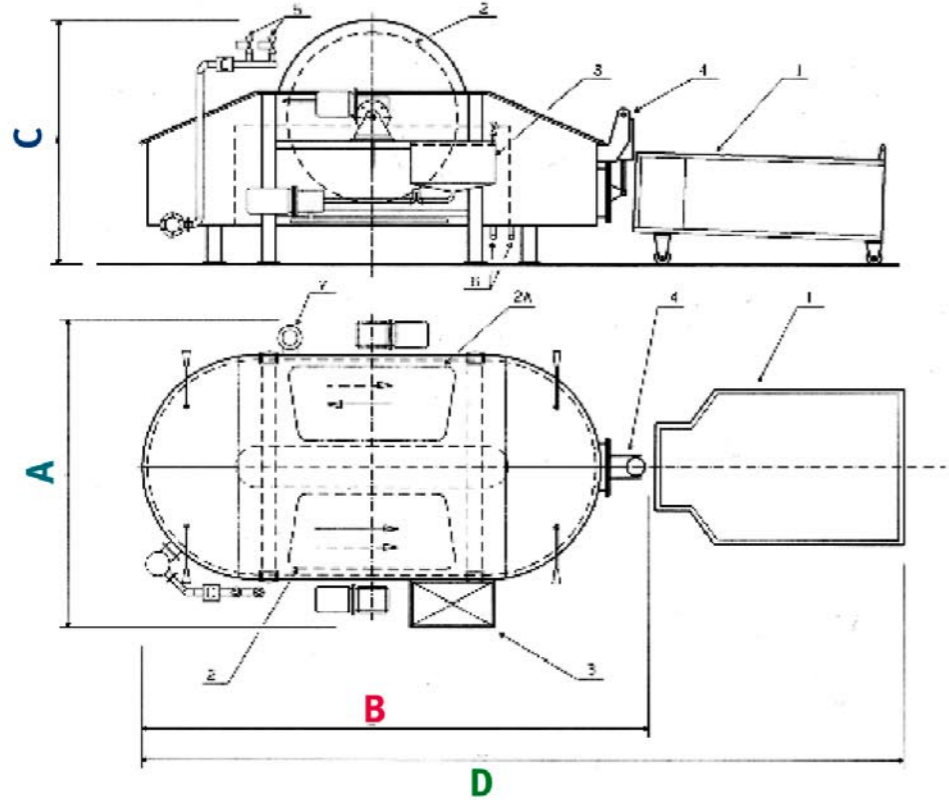

Flainox s.r.l.

Macchine tessili per tintoria e finissaggio - 13854 Quaregna (BI) - Italy - Via G. Leopardi, 5
 Tel. +39 015.98.06.80 - Fax +39 015.94.771 - e-mail: comm@flainox-it.com - www.flainox-it.com

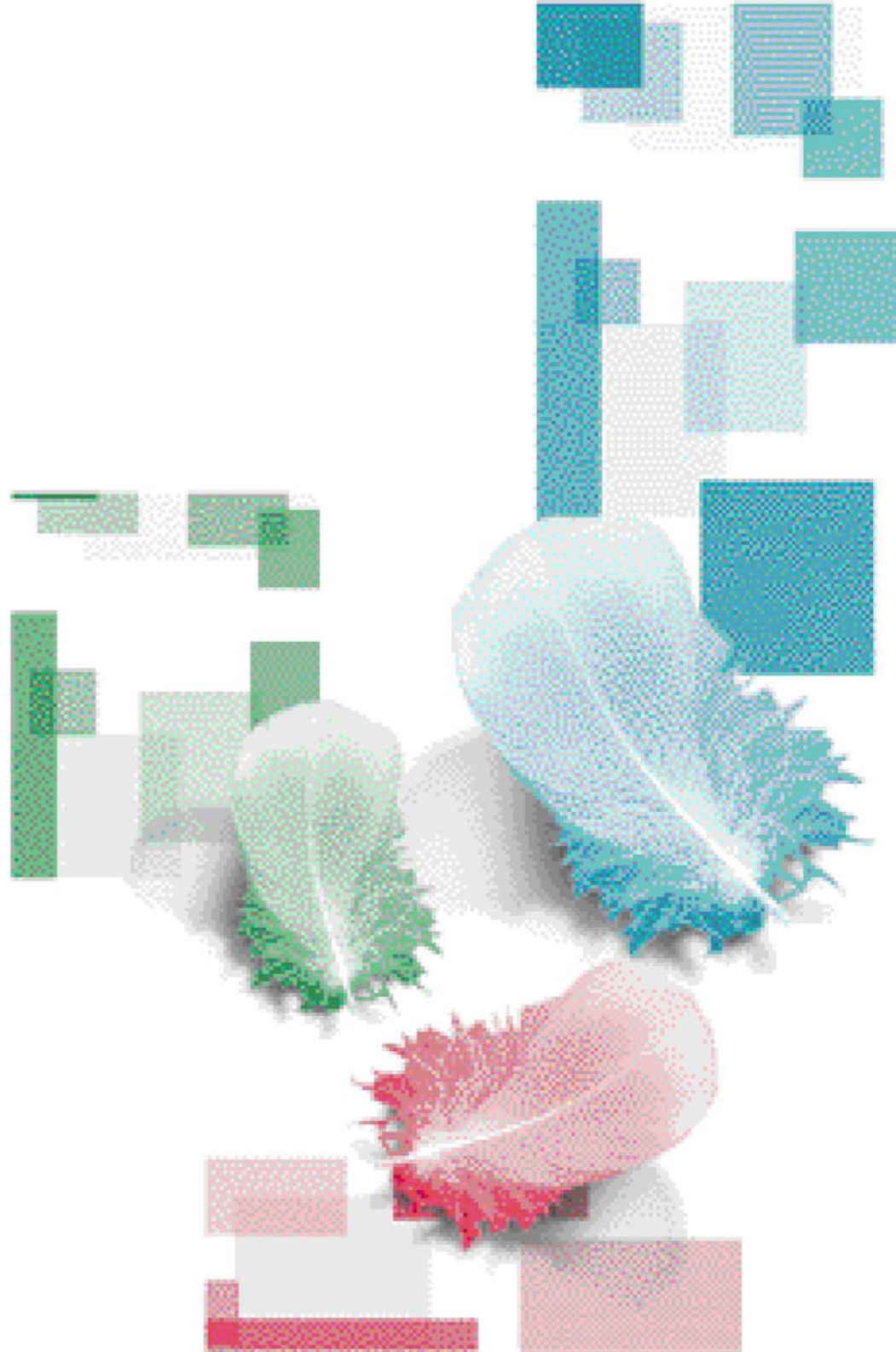

Stampa: Litotecnica Magliola - Biella
 www.modesit.it