

# GHIBLI XSL

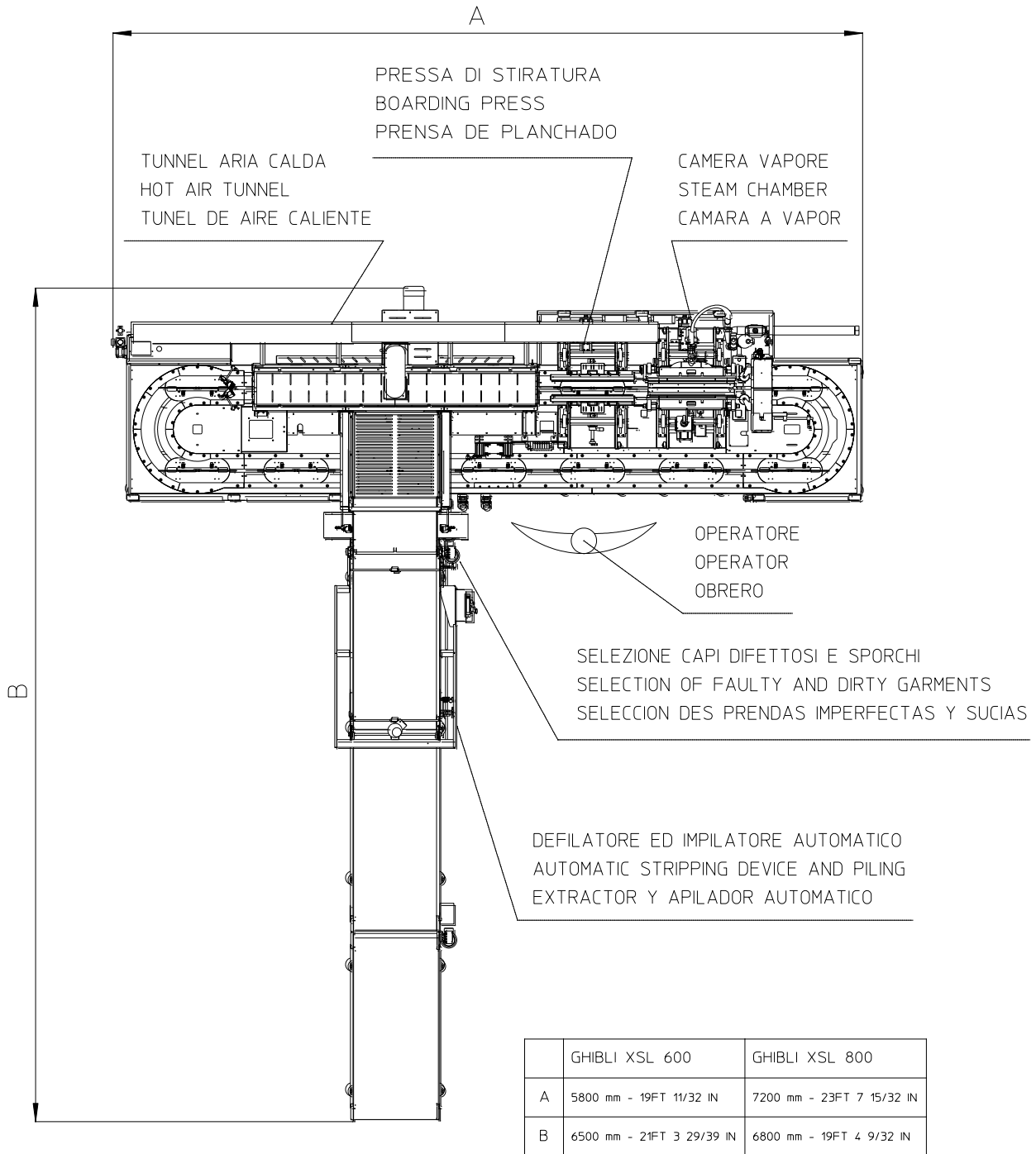

**GHIBLI XSL600 H=2300 mm - 7 FT 6 35/64 IN**

**GHIBLI XSL800 H=2400 mm - 7 FT 10 31/64 IN**

# GHIBLI XSL TECHNICAL DATA

		XSL 600	XSL 800
Weight	Kg	3400	3900
Operators	N°	1	1
Boarding Forms	N°	12/14	12/14
Max Cycle	sec	6	6
Max Production	p/h	600	600
Air Pressure	bar	6	6
Max air consumption	mc/h	25	25
Steam max pressure	bar	3	3
Steam max consumption	Kg/h	25	25
Installed power	Kw	24	36
Voltage	Volt	400	400
Pressl max temperature	°C	250	250
Tunnel max temperature	°C	250	250
Dimensions	mm	5800 x 6500 x 2300	7200 x 6800 x 2400

**TECNOPEA s.r.l.** Via Don Eridano Torri, 2 – 25027 Quinzano D'Oglio BRESCIA ITALIA

P.IVA: 01595230986 - Tel. +39 030 9923780 Fax. +39 030 9923996 E-mail:

[info@tecnopea.it](mailto:info@tecnopea.it)

**TECNOPEA s.r.l.** has the right to modify at any time and without notice the features of the machines shown on this site.