

# FST

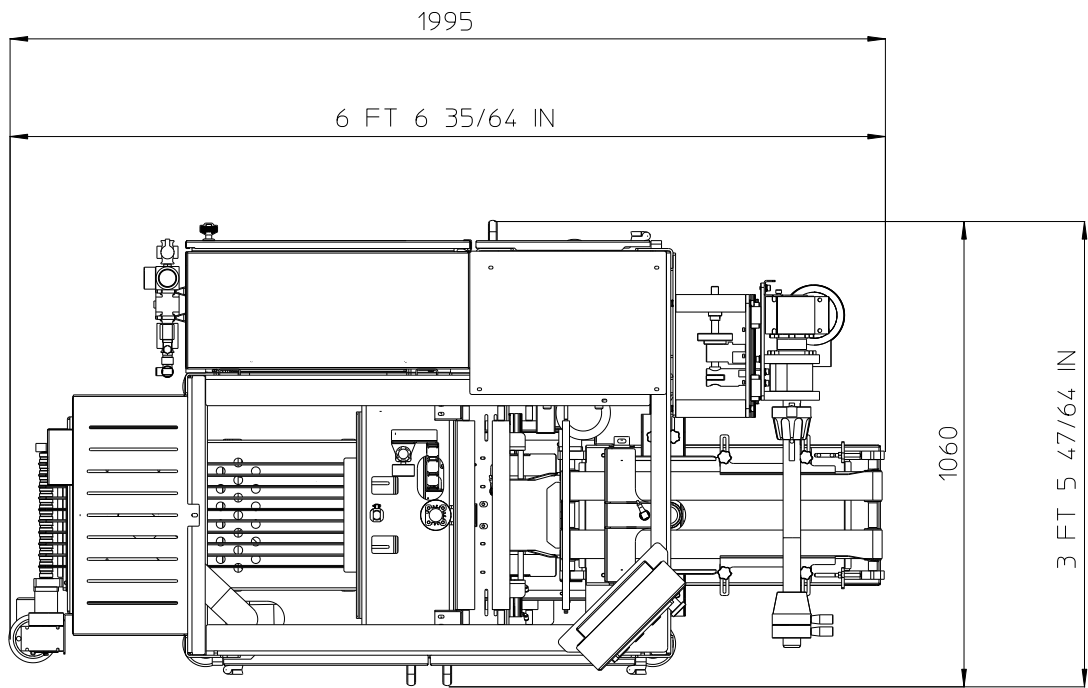
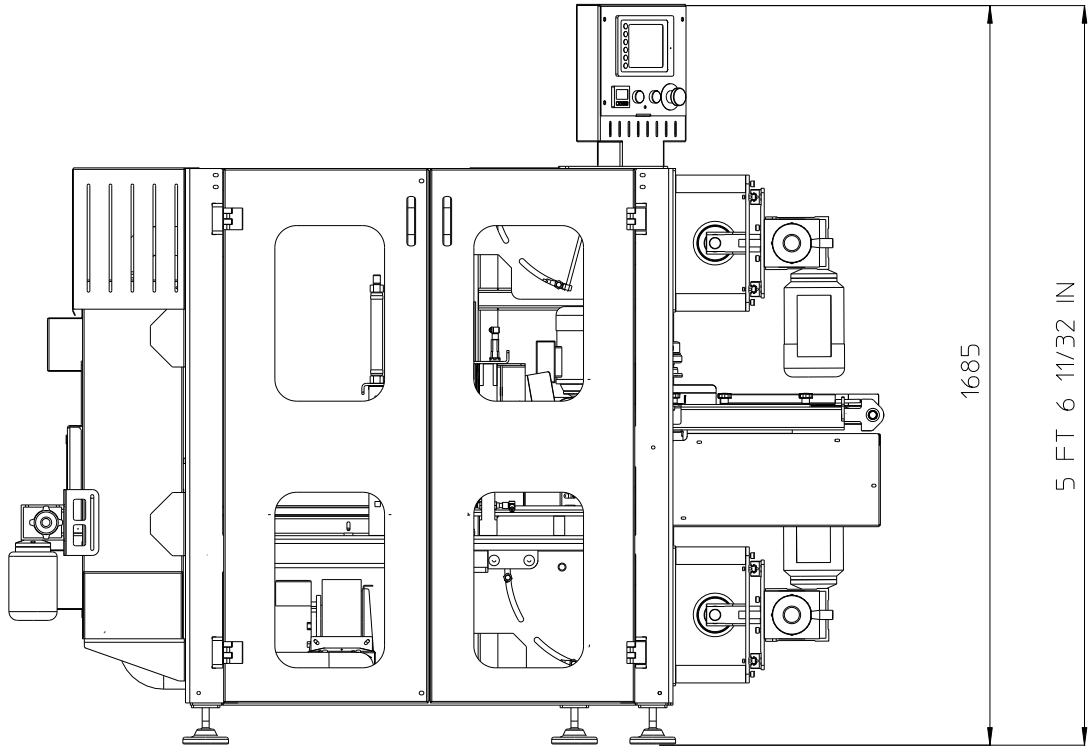

# FST TECHNICAL DATA

		DATI
Weight	kg	1400
Air Pressure	bar	6
Air max consumption	mc/h	4.5
Installed power	kW	6
Min Cycle	Sec	7
Bag length	mm	160÷245
Bag width	mm	110÷160
Polypropylene film width	mm	200÷420
Voltage	Volt	400
Dimensions	mm	1995x 1060X 1685

**TECNOPEA s.r.l.** Via Don Eridano Torri, 2 – 25027 Quinzano D'Oglio BRESCIA ITALIA

P.IVA: 01595230986 - Tel. +39 030 9923780 Fax. +39 030 9923996 E-mail:

[info@tecnopea.it](mailto:info@tecnopea.it)

**TECNOPEA s.r.l.** has the right to modify at any time and without notice the features of the machines shown on this site.